

## Product Information



### **AST4930** Petrol Engine Twin Camshaft Setting/Locking Tool Kit



**IMPORTANT:** Always refer to the vehicle manufacturer's service instructions, or proprietary manual, to establish the current procedures and data. Product Information Sets detail applications and use of the tools with any general instructions provided as a guide only.



#### **Applications:**

**FORD 1.6 Ti-VCT Twin Camshaft 16v.**  
Duratec Petrol engine in

#### **FORD**

Focus C-Max Mondeo

#### **HXDA engines**

#### **Additional AST Tools required**

AST4844 Sprocket Holding Tool  
(to counter-hold crankshaft pulley)

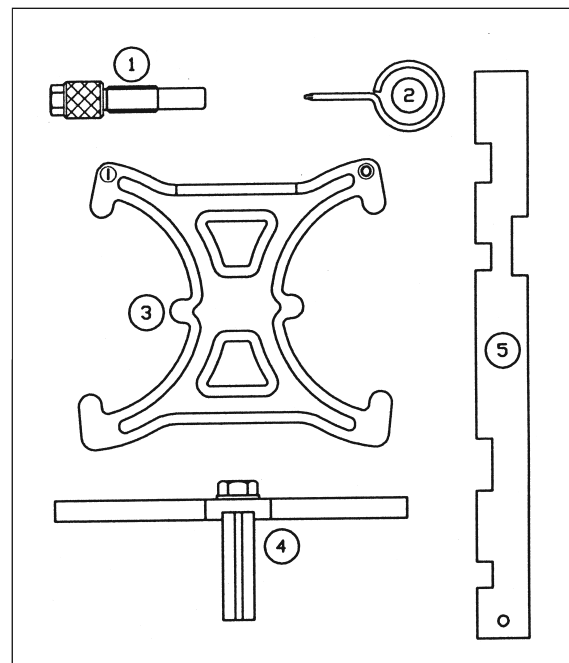

#### **Kit contents/spares**

<b>Item</b>	<b>Part Number</b>	<b>Description</b>
1	AST3032-21	Crankshaft TDC Location Pin
2	AST4640T7	Tensioner Locking Pin
3	AST4931	VCT Setting Plate
4	AST4832	Flywheel Locking Tool
5	AST4933	Camshaft Setting Plate
-	AST4930-84	Case + Insert

## AST4930 Petrol Engine Setting/Locking Tool Kit

Comprises **AST3032-21 Crankshaft TDC Location Pin**  
**AST4640T7 Tensioner Locking Pin**  
**AST4832 Flywheel Locking Tool**  
**AST4931 VCT Setting Plate**  
**AST4933 Camshaft Setting Plate**

AST4930 Setting/Locking Tool Kit provides the timing tools required for timing belt replacement applications PLUS to cover VCT timing adjustment.



The Ford 1.6 16v. Ti VCT Duratec (Sigma) petrol engine was first introduced in the Ford Focus in 2004. The engine has variable camshaft timing (VCT) on both the inlet and exhaust camshafts.

### Timing Belt Replacement

Raise and support the front of the vehicle in order to remove the right-hand front road wheel.

Remove the air filter housing/assembly, PAS reservoir (do not disconnect) and auxiliary belt.

Remove alternator and starter motor. Detach the coolant expansion tank (do not disconnect), and position to one side.

Remove the coolant pump pulley and upper timing belt cover.

Turn the crankshaft until the timing marks on the VCT Units are in the 11-o'clock position (crankshaft is just before TDC No.1 cylinder).

**NOTE:** The crankshaft must only be turned in the direction of normal rotation.

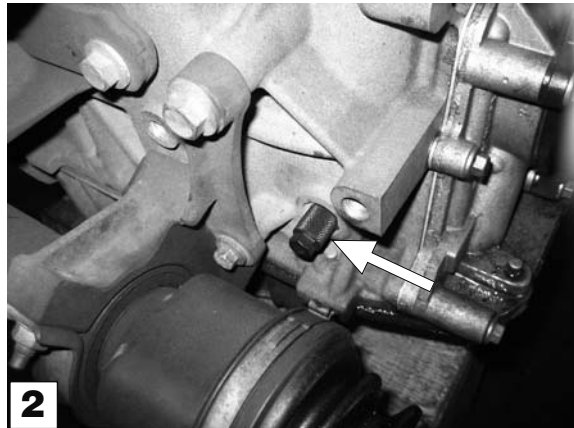

### AST3032-21 Crankshaft TDC Location Pin

Remove the blanking plug in the engine block, in order to insert the AST3032-21 Crankshaft Location Pin.

Carefully and slowly, turn the crankshaft **clockwise** to **rest fully** on the AST3032-21 Location Pin.

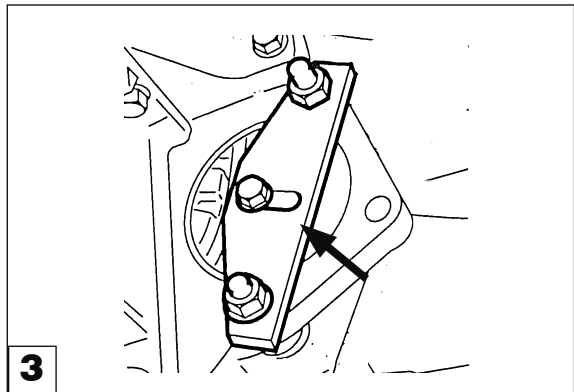

### AST4832 Flywheel Locking Tool

Ensure the crankshaft is fully resting on the AST3032-21 Location Pin and 'lock' the flywheel by installing AST4832 Flywheel Locking Tool at the starter motor position.

The camshaft timing marks should be at 12-o'clock position. The marks are located on front of the sprocket teeth – "I" on the left-hand sprocket and "•" on the right-hand sprocket.

Remove the crankshaft pulley and discard its centre bolt. Remove the lower belt cover.

Support the engine and remove the front engine mounting bracket after marking its installed position.



#### AST4931 VCT Setting Plate

Fit AST4931 VCT Setting Plate onto the VCT Units. The word "TOP" should be visible on top of the Setting Plate. The "Scribe Mark I" should be on the left-hand arm of the Setting Plate, with the "Zero (Dot) Mark 0" on the right-hand arm of the Plate, matching the timing marks on the camshaft sprockets.

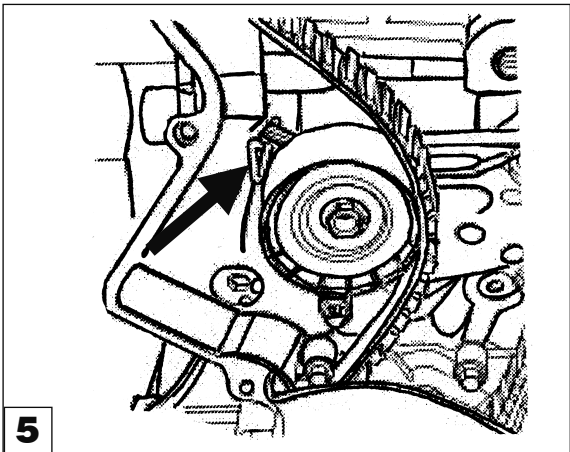

#### AST4640T7 Tensioner Locking Pin

Apply pressure to the timing belt to activate the tensioner pulley and allow the insertion of Locking Pin AST4640T7.

Remove the old timing belt and discard.

#### Installing new belt

Check that the VCT Setting Plate, Crankshaft Location Pin and Flywheel Locking Tool are correctly fitted.

Install the new timing belt in a **clockwise** direction, starting at the VCT Units/camshaft sprocket, then the crankshaft gear. Ensure the belt is taut between sprockets.

Once the belt is fully fitted, remove the AST4640T7 Tensioner Locking Pin to release tension on to the belt.

Measure the depth of the bore in the crankshaft to determine the correct new crankshaft pulley centre bolt to use.

- If bore depth is 42mm. – use M12 x 29mm. bolt
- If bore depth is 52mm. – use M12 x 44.5mm. bolt.

Install the lower belt cover.

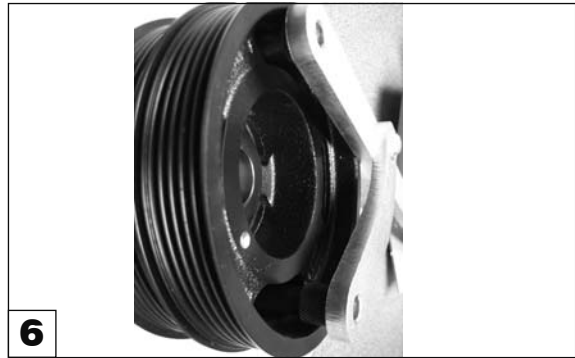

Install the crankshaft pulley, counter-hold pulley with a suitable Holding Tool, such as AST4844, whilst tightening centre bolt, in two stages, 45Nm. + 90 degrees.

**NOTE:** Crankshaft gear does not have a keyway

Remove the VCT Setting Plate, Crankshaft Location Pin and Flywheel Locking Tool.

Turn the crankshaft carefully, by hand, 2 turns in the direction of normal rotation and return to the position where the marks on the VCT Units are at 11-o'clock.

Insert AST3032-21 Crankshaft Location Pin and carefully turn the crankshaft to **rest fully** on the Location Pin.



Fit AST4931 VCT Setting Plate on to the VCT Units and check that the timing marks on the **VCT Units and camshaft sprockets** align and are near to the outer edges of the Setting Plate upper arms.

If the timing marks do not align, repeat the belt installation and tensioning procedures.

## Timing Adjustment - Setting the VCT Units (Cylinder head/Camshaft replacement applications)

When carrying out work on cylinder head / camshaft replacement or valve timing adjustment it will be necessary to re-set the VCT / camshafts.

When removing the VCT Units, counter-hold the camshafts, with a spanner, at the hexagons provided on the camshafts. Remove the centre blanking plugs of the VCT Units, and unscrew and remove the centre retaining bolts.

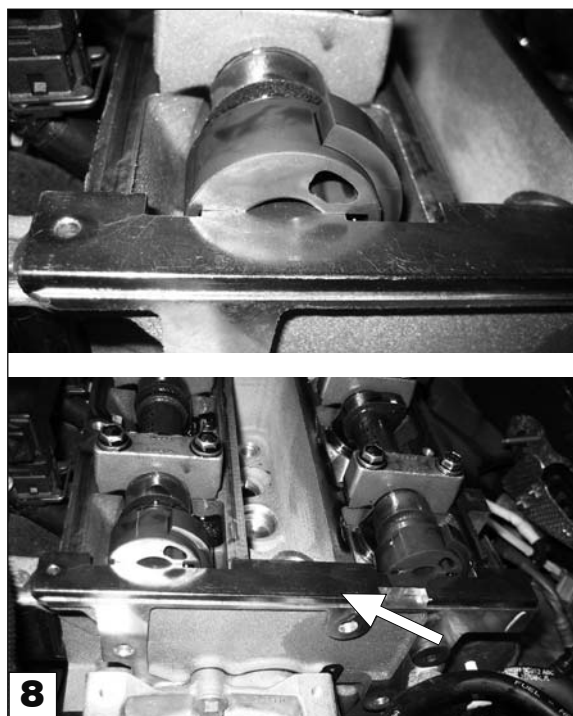

### AST4933 camshaft Setting Plate

When installing the VCT Units, the crankshaft is positioned at TDC No.1 cylinder and AST4933 Camshaft Setting Plate is inserted into the slots located at the rear of the camshafts to position the camshafts in their 'timed' position.

The VCT Units are placed onto the camshafts and the new centre retaining bolts are inserted and screwed to finger-tight only.

The timing mark of each of the VCT Units should be positioned at the 12-o'clock position.

AST4931 Setting Plate is inserted onto the VCT Units and the centre bolts tightened to 25Nm.

Remove AST4931 and AST4933 Setting Plates.

Counter-hold the camshafts, with a spanner, at the hexagons provided on the camshafts and carry out the final tightening procedure – tightening the VCT centre retaining bolts 75 degrees.

**WARNING: DO NOT use AST4931 and AST4933 Setting Plates to counter-hold camshafts/VCT Units during final tightening procedure of the VCT Units retaining bolts.**

Insert AST4931 Setting Plate to check that the timing position is correct and that the timing marks on the sprockets align with the marks on the VCT Units near to the outer edges of AST4931 Setting Plate upper arms.